



Amphenol

Fiber Optic Solutions

DEPLOYABLE CABLE DRUMS

deployable drums & accessories
harsh environment

Deployable cable drums

Amphenol can offer a wide range of cable drums designed to cater for deployable harsh environment optical links. Drums are available in a variety of applications, sizes, materials, accessories, and for various diameters and lengths of cable.

TACTICAL DRUMS

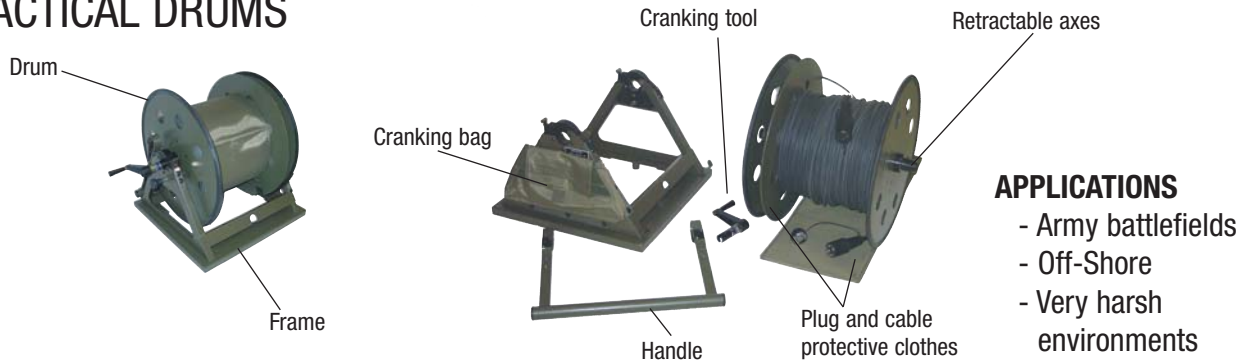

TECHNICAL INFORMATION

Nominal capacity is calculated with $\varnothing 5.5\text{mm}$ cable, for 65% of the theoretical maximum capacity.

APPLICATION		OPTICAL LINKS						COAX	ENERGY	
			T06	T05	T01	T03	T04	T07	T00	T13
DRUMS	OVERALL DIMENSIONS (mm)	C	255	255	257	257	257	570	257	166
		L	335	335	335	335	335	650	335	335
		$\varnothing D$	240	280	370	420	550	550	450	450
		$\varnothing E$	230	270	355	405	535	535	415	415
		$\varnothing d$	140	140	180	180	180	180	180	180
WEIGHT (kg) without cable			3	3.4	4.5	5.5	8	19	5.9	6.1
CAPACITY (m) with cable $\varnothing 5.5\text{mm}$			100	200	350	500	1000	2200	620	400
FRAME	OVERALL DIMENSIONS (mm)	W	440	440	440	440	440	755	440	440
		H	185	185	255	255	320	320	255	255
		P	300	300	440	440	440	440	440	440
		S	18	18	30	30	30	30	30	30
		Ap/Aw	200/340	200/340	390/340	390/340	390/340	390/630	390/340	390/340
WEIGHT (kg)			4	4	6.65	6.65	7.65	12	6.65	6.65
ACCESSORIES (option)	CRANKING TOOL		X	X	X	X	X	X	X	X
	HANDLE		X	X	X	X	X	X	X	X
	INNER SEPARATION FOR TWO PATCHCORDS					X				
	CRANK BAG		X	X	X	X	X	X	X	X
	PLUG AND CABLE PROTEC. CLOTHES		X	X	X	X	X	X	X	X
SHELLS FINISH			Nato Green/Black	Nato Green/Black	Nato Green/Black	Nato Green/Black	Nato Green/Black	Nato Green/Black	Nato Green/Black	
RUGGEDIZED VERSION	standard		*	*	*	*	*	*	*	
	option				**	**		**	**	

* : reinforced / ** : super reinforced

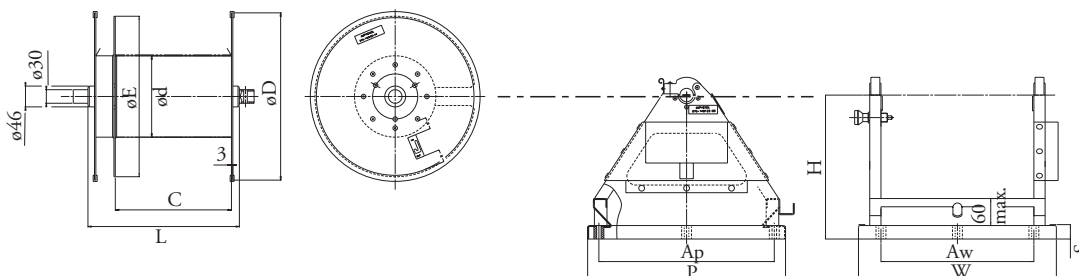

Deployable cable drums



COMPACT DRUMS

Drum type LX

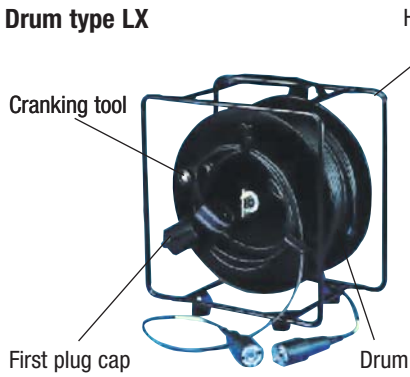

APPLICATIONS

- Army battlefields
- Off-shore
- Industrial

Drum type D

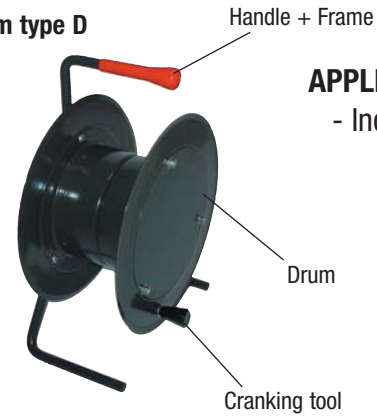

APPLICATIONS

- Industrial

TECHNICAL INFORMATION

Nominal capacity is calculated with $\varnothing 5.5\text{mm}$ cable, for 65% of the theoretical maximum capacity

			L1	L2	L3	L34	L36	D
DRUMS + FRAME (integrated)	OVERALL DIMENSIONS (mm)	C	125	150	300	450	600	130
		L	230	350	500	650	800	200
		ØD	320	450	450	450	450	288
		Ød	90	230	230	230	230	155
		A	360	520	520	520	520	280
		B	400	540	540	540	540	400
WEIGHT (kg) without cable			6.25	9.75	11.25	13	14.5	4
CAPACITY (m) with cable $\varnothing 5.5\text{mm}$			150	300	600	1000	1300	100
ACCESSORIES	CRANKING TOOL (integrated)		X	X	X	X	X	X
	HANDLE + FRAME (integrated)		X	X	X	X	X	X
	2 ELASTICS BELTS FOR PLUG (integrated)							X
	OUTER CABLE PROTECT CLOTHES (option)			X	X	X	X	
	FIRST PLUG BAG (option)			X	X	X	X	
	INNER CABLE PROTECT. CLOTHES			X	X	X	X	
	SHELLS FINISH			Black	Black	Black	Black	Black

Type L2, L3, L34, L36 drums

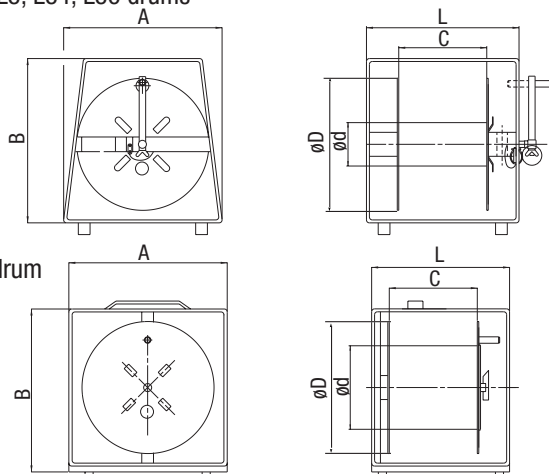

Type L1 drum

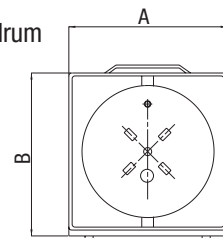

Type D drum

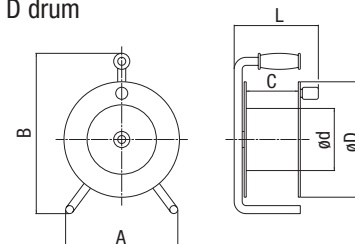

NORTH AMERICA

AMPHENOL Pcd, Inc.

2 Technology Drive
Peabody, MA 01960
Telephone: 1-978-532-8800
Fax: 1-978-532-6800

AMPHENOL AEROSPACE OPERATIONS AMPHENOL INDUSTRIAL OPERATIONS

40-60 Delaware Street
Sidney, New York 13838-1395 - USA
Telephone: 1-607-563-5011
Fax: 1-607-563-5157

AMPHENOL BACKPLANE SYSTEMS

18 Celina Avenue
Nashua, New Hampshire 03063 - USA
Telephone: 1-603-883-5100
Fax: 1-603-883-0171

AMPHENOL CANADA CORPORATION

20 Melford Drive - Scarborough, Ontario M1B 2X6
Canada
Telephone: 1-416-291-4401 Fax: 1-416-292-0647
1870 boul. des Sources, Suite 204
Pointe Claire, Quebec H9R 5N4 - Canada
Telephone: 1-514-630-7242 ext. 225
Fax: 1-514-630-7697

AMPHENOL FIBER OPTIC PRODUCTS- RICHARDSON OPERATION

1778 North Plano Road, Suite 212
Richardson, Texas 75081
Telephone: 1-972-744-9801
Fax: 1-972-744-9022

AMPHENOL FSI

1300 Central Expwy N, Suite 100
Allen, TX 75013 U.S.A.
Toll-Free: 800-472-4225 - Fax: 214-547-9344
info@fibersystems.com

EUROPE

AMPHENOL SOCAPEX

MIL-AERO & INDUSTRIAL Business Unit
948 Promenade de l'Arve - B. P. 29
74311 Thyez Cedex - France
Telephone: 33-4-5089-2800
Fax: 33-4-5096-1941

AMPHENOL LIMITED WHITSTABLE

Thanet Way, Whitstable - Kent, CT5 3JF
United Kingdom
Telephone: 44-1227-773-200
Fax: 44-1227-276-571

AMPHENOL LIMITED NOTTINGHAM

Unit D1 Crossgate Drive, Queens Drive Industrial
Estate - NG2 1LW - Nottingham - United Kingdom
Telephone: 44-1159-866-200
Fax: 44-1159-866-212

AMPHENOL AIR LB GmbH

Am Kleinbahnhof 4 - 66740 Saarlouis Germany
Telephone: 49-6831-981-00
Fax: 49-6831-981-030

AMPHENOL ITALIA

Via Barbaiana n. 5, 20020 Lainate - Milano - Italy
Telephone: 39-293-55-03-71
Fax: 39-348-361-7249

AMPHENOL IBERICA

C/Calderon de la barca, 3 4A, 28 100 Alcobendas,
Madrid - Spain
Telephone: 34-91-654-83-52
Fax: 34-91-640-73-07

AMPHENOL SCANDINAVIA

Snosvängen 14 13466 Ingarö - Sweden
Telephone: 46-8-571-423-90
Fax: 46-8-571-423-89

AMPHENOL BENELUX

Zadelmaker 121 NL-2401 PD Alphen aan den Rijn
The Netherlands
Telephone: 31-172-444-903
Fax: 31-172-240-254

AMPHENOL CENTRAL EUROPE

Topolowa 13, 41 600 Swietochlowice - Poland
Telephone: 48-32-3484-201 - Fax: 48-32-3484-202

AMPHENOL EUROPEAN SALES OPERATIONS

Hoofdveste 19 - 3992 DH Houten - The Netherlands
Telephone: 31-30-635-8000 - Fax: 31-30-637-7034

ASIA

CHINA (FOP)

3rd Floor, The 4th Ind. District of Ind.
Headquarters Dong Keng Road, Gong Ming Town
Shenzen 518132, Guangdong Province - PR China
Telephone: 86-755-717-7945
Fax: 86-755-717-7622

AMPHENOL TAIWAN CORPORATION

No. 116, Lane 956, Zhong Shan Road
Taoyuan City, R. O. C., 330 - Taiwan
Telephone: 886-3-379-5677
Fax: 886-3-360-7259 Sales/CS/Eng./QA/MIS

AMPHENOL EAST ASIA LIMITED

2201 Railway Plaza, 39 Chatham Road South
Tsmishatsui, Kowloon - Hong Kong
Telephone: 852-2699-2663
Fax: 852-2691-1774

AMPHENOL INTERCONNECT INDIA PRIVATE LIMITED

105 Bhosari Industrial Area - Pune 411 026 - India
Telephone: 91-20-712-0363/0463/0155
Fax: 91-20-712-0581

AMPHENOL JAPAN MIL/AERO INDUSTRIAL

689-1, Iseochi, Ritto-shi Shiga 520-3044 - Japan
Telephone: 81-77-553-8501
Fax: 81-77-551-2200

AMPHENOL DAESHIN

558 Sosa, SongNea
Bucheon-city, Kyunggi-Do - Korea 420-130
Telephone: 82-32-610-3800
Fax: 82-32-673-2507/665-6219

REST OF THE WORLD

AMPHENOL MEXICO

Prolongacion Reforma 61-6 B2
Col. Paseo de las Lomas - C.P. 013130 Mexico
Telephone: 52-55-5258-9984
Fax: 52-55-5081-6890

AMPHENOL SOUTH AFRICA

30 Impala Road
2196 Chislehurst-Sandton - South Africa
Telephone: 27-11-783-9517 - Fax: 27-11-783-9519

BAR TEC LTD

4 Hagavish St, PO Box 279 - Kfar Saba 44102 -
Israel
Telephone: 972-9-767-4097
Fax: 972-9-767-4324

GESTAS

34630, Besyol Londra Asfalti
Florya is Merkezi Kat.2 - Sefakoy / Istanbul - Turkey
Telephone: 90-212-624-52-29
Fax: 90-212-599-30-68

AMPHENOL ARGENTINA

"Av. Callao 930 2do piso Oficina B "Plaza"
C1023" - AAP Buenos Aires - Argentina
Telephone: 54-11-4815-6886
Fax: 54-11-4814-5779

TFC SOUTH AMERICA

BUENOS AIRES, ARGENTINA

Local Sales Office - Tucuman 540 - Suite 28 "C"
C1049AAL- Buenos Aires - Argentina
Telephone: 54-11-4325-3471
Fax: 54-11-4327-1339

AMPHENOL AUSTRALIA PTY LIMITED

2 Fiveways Blvd., Keysborough
Melbourne, Victoria 3173 - Australia
Telephone: 61-3-8796-8888
Fax: 61-3-8796-8801

AMPHENOL DO BRAZIL

Rua Diogo Moreira, 132, 20 andar, rooms 2001-2-3
CEP: 05423-010 Sao Paulo SP - Brazil
Telephone: 55-11-3815-1003
Fax: 55-11-3815-1629

Amphenol reserves the right to change the content of this document without prior notice

Amphenol
Fiber Optic Solutions

Realisation : wagen:studios - Steven Kilgallon - 01/2004
Printed in France by MenloPark

For more informations, please consult our website :
www.amphenol-fiberopticsolutions.com

DOC-000504-ANG